

Approval body for construction products
and types of construction

Bautechnisches Prüfamt

An institution established by the Federal and
Laender Governments



European Technical Assessment

ETA-13/0151
of 14 November 2019

English translation prepared by DIBt - Original version in German language

General Part

Technical Assessment Body issuing the
European Technical Assessment:

Deutsches Institut für Bautechnik

Trade name of the construction product

PEIKKO PSB punching reinforcement

Product family
to which the construction product belongs

Double headed studs as punching reinforcement

Manufacturer

Peikko Group Oy
Voimakatu 3
15101 LAHTI
FINNLAND

Manufacturing plant

Peikko Manufacturing plants

This European Technical Assessment
contains

18 pages including 3 annexes which form an integral part
of this assessment

This European Technical Assessment is
issued in accordance with Regulation (EU)
No 305/2011, on the basis of

EAD 160003-00-0301

This version replaces

ETA-13/0151 issued on 4 September 2018

The European Technical Assessment is issued by the Technical Assessment Body in its official language. Translations of this European Technical Assessment in other languages shall fully correspond to the original issued document and shall be identified as such.

Communication of this European Technical Assessment, including transmission by electronic means, shall be in full. However, partial reproduction may only be made with the written consent of the issuing Technical Assessment Body. Any partial reproduction shall be identified as such.

This European Technical Assessment may be withdrawn by the issuing Technical Assessment Body, in particular pursuant to information by the Commission in accordance with Article 25(3) of Regulation (EU) No 305/2011.

Specific Part

1 Technical description of the product

The PSB double headed studs with ribbed shafts are made of weldable ribbed reinforcement bars with nominal characteristic yield strength of 500 MPa. The mechanical properties of the steel used meet the requirement according to EN 1992-1-1, Annex C.

They have a head at both ends with a diameter of three times the shaft diameter.

The diameters of the shafts are 10, 12, 14, 16, 20 and 25 mm.

The studs are assembled to form reinforcement elements comprising at least two studs (see Annex A1). The studs are tack welded or clamped at one end to a non-structural steel rail or steel bars (reinforcing bars or round bars) for securing the position of the double headed studs when pouring the concrete. For use in semi-prefabricated slabs only, steel rails in connection with special plastic connectors (clip-on plastic connectors) are used to secure the placement during casting. All studs of one of those reinforcement element shall have the same diameter.

The bars used to secure the stud's position during casting (assembly profile) are made of weldable reinforcing steel or structural steel (smooth steel bars) $d_s = 6$ mm to $d_s = 10$ mm and the rails are made of structural steel with a thickness of $t = 4$ mm. The material for the structural steel (bars or rails) shall be No. 1.0037, 10038 or 1.0045 acc. to EN 10025-2 or non-corrosive steel No. 1.4401, 1.4404, 1.4439, 1.4571 acc. to EN 10088-5. The material of the clip-on plastic connectors for use in semi-prefabricated slabs is specified within the technical documentation deposited with Deutsches Institut für Bautechnik.

The detailed product description is given in Annex A.

2 Specification of the intended use in accordance with the applicable European Assessment Document

The performances given in Section 3 are only valid if the Product is used in compliance with the specifications and conditions given in Annex B.

The verifications and assessment methods on which this European Technical Assessment is based lead to the assumption of a working life of the Product of at least 50 years. The indications given on the working life cannot be interpreted as a guarantee given by the producer, but are to be regarded only as a means for choosing the right products in relation to the expected economically reasonable working life of the works.

3 Performance of the product and references to the methods used for its assessment

3.1 Mechanical resistance and stability (BWR 1)

Essential characteristic	Performance
Increasing factor for punching shear resistance	$k_{pu,sl} = 1,96$ $k_{pu,fo} = 1,62$
characteristic fatigue strength for $N = 2 \cdot 10^6$ load cycles	$\Delta\sigma_{Rsk,n=2 \cdot 10^6} = 70$ MPa

3.2 Safety in case of fire (BWR 2)

Essential characteristic	Performance
Reaction to fire	class A1

4 Assessment and verification of constancy of performance (AVCP) system applied, with reference to its legal base

In accordance with EAD No. 160003-00-0301 the applicable European legal act is: [97/597/EC(EU)].

The system(s) to be applied is (are): [1+]

In addition, with regard to reaction to fire for products covered by this EAD the applicable European legal act is: [2001/596/EC(EU)]

The system to be applied is: [4]

5 Technical details necessary for the implementation of the AVCP system, as provided for in the applicable EAD

Technical details necessary for the implementation of the AVCP system are laid down in the control plan deposited with Deutsches Institut für Bautechnik.

Issued in Berlin on 14 November 2019 by Deutsches Institut für Bautechnik

BD Dipl.-Ing. Andreas Kummerow
Head of Department

beglaubigt:
Schüler

PSB Double-Headed Studs - Element

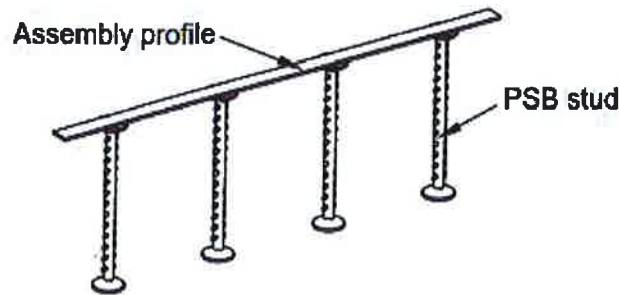

PSB stud dimensions

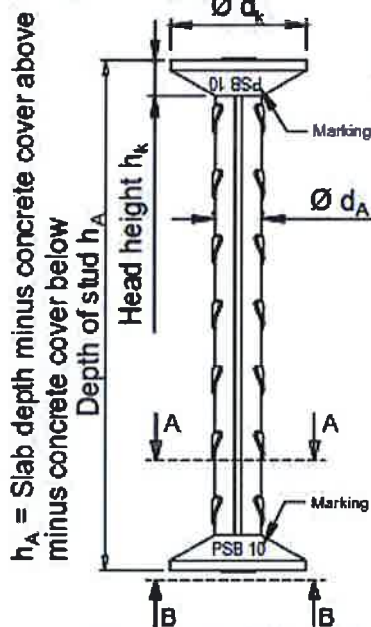

Identifying marking on both (heads/ends)

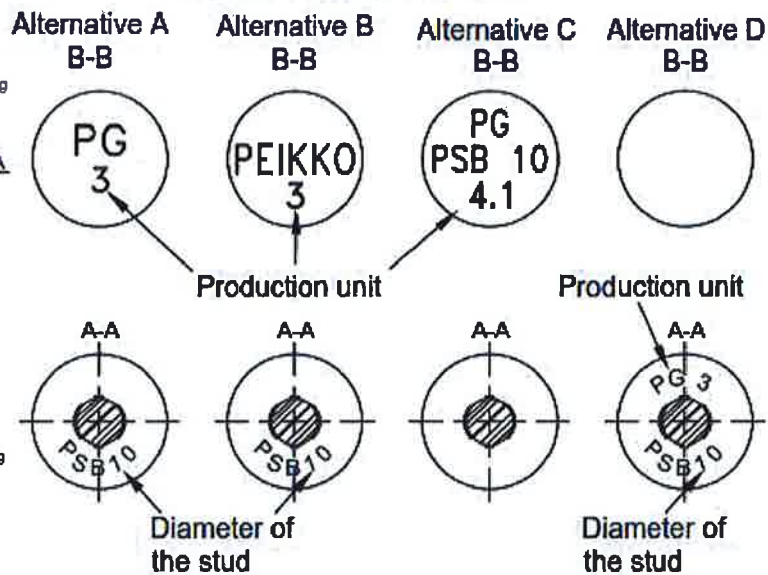

Material: Reinforcing steel with characteristic yield strength $f_{yk} \geq 500$ MPa acc. to EN 1992-1-1 Annex C and data sheet deposited at DIBt

Diameter of the stud d_A [mm]	Diameter of the head d_k [mm]	Head thickness h_k [mm]	Section of the stud A [mm ²]	Characteristic value of yield strength f_{yk} [MPa]	Characteristic value of tensile strength of the stud $F_k = A \cdot f_{yk}$ [kN]
10	30	5	79	500	39,3
12	38	6	113		56,5
14	42	7	154		77,0
16	48	7	201		100,5
20	60	9	314		157,1
25	75	12	491		245,4

PEIKKO PSB Punching Reinforcement

Product description
PSB stud dimensions and types

Annex A1

Assembly profile from reinforcement bars or round bars

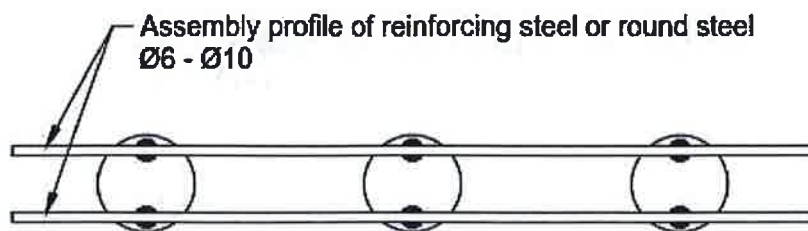

Material:

Reinf. steel: Reinforcing steel with characteristic yield strength $f_{yk} \geq 500$ MPa acc. to EN 1992-1-1 Annex C and data sheet deposited at DIBt

Round steel: S235 JR (EN 10025-2:2004)
A4 = 1.4571/1.4401/1.4404 (EN 10088-5:2009)

Assembly profile from flat bars

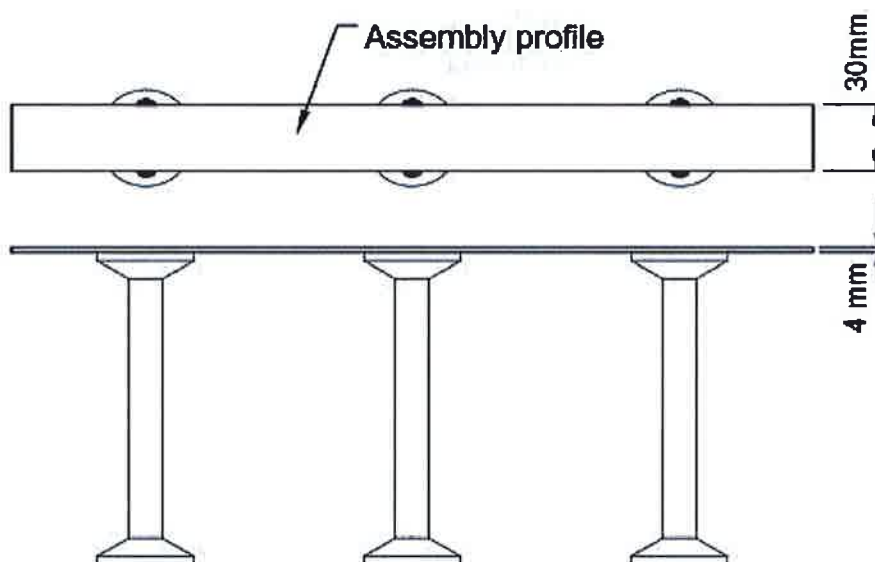

Material: S235JR = 1.0038 (EN 10025-2:2004)

PEIKKO PSB Punching Reinforcement

Product description
Assembly profiles for PSB Punching Reinforcement

Annex A2

PSB-F reinforcing elements for precast element

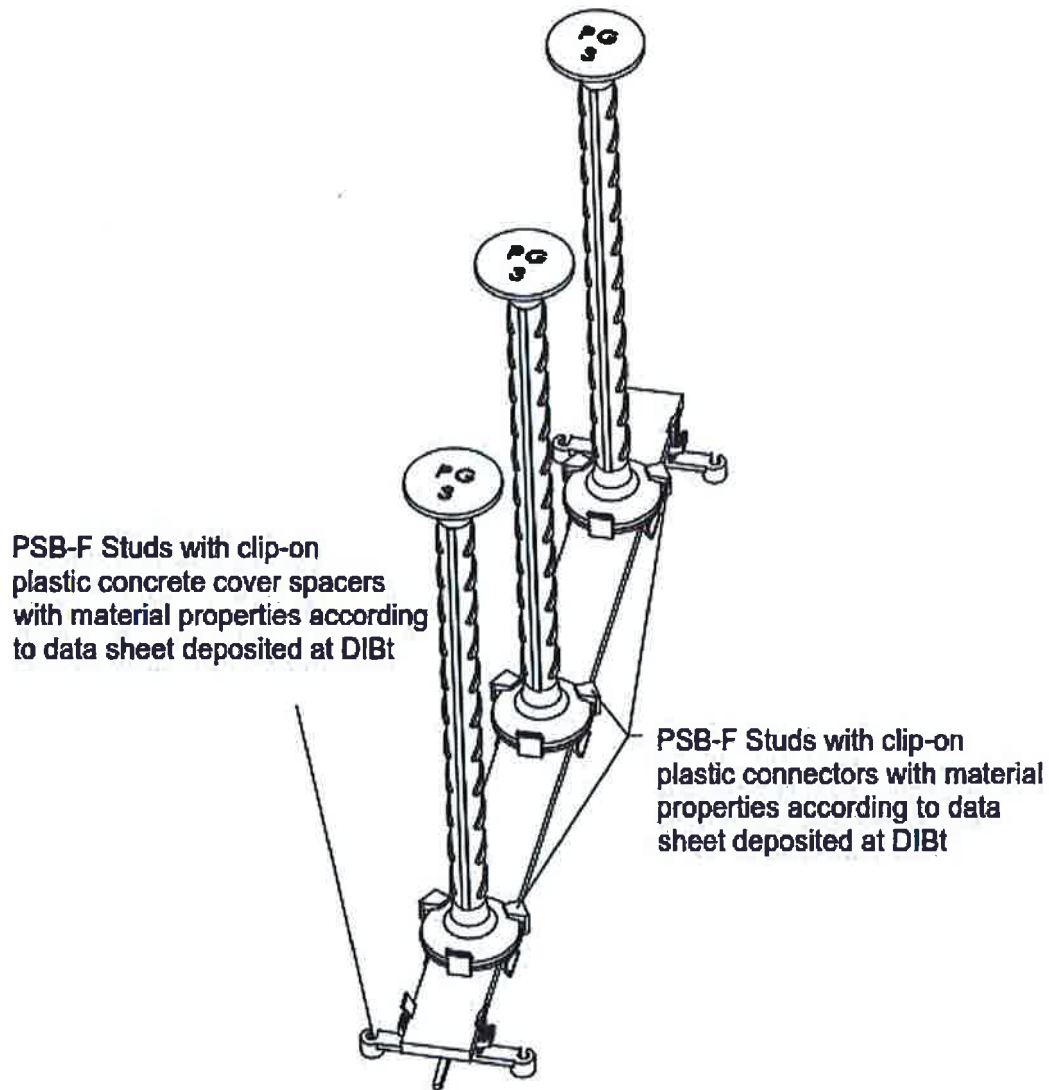

PEIKKO PSB Punching Reinforcement

Product description
PSB Punching Reinforcement for precast elements

Annex A3

Specification of intended use

The reinforcement elements with double headed studs are intended to be used for the increase of the punching shear resistance of flat slab or footing and ground slabs under static, quasi-static and fatigue loading. The reinforcement elements with double headed studs are located adjacent to columns or high concentrated loads. The design of the punching shear resistance of flat slabs or footings and ground slabs is done in accordance with EOTA TR 060.

The intended use covers the following specifications:

- flat slabs or footings and ground slabs made of reinforced normal weight concrete of strength class C20/25 to C50/60 according to EN 206-1 :2013
- flat slabs or footings and ground slabs with a minimum height of $h = 180$ mm
- flat slabs or footings and ground slabs with a maximum effective depth of $d = 300$ mm (only for double headed studs with smooth shafts)
- reinforcement elements with double headed studs of the same diameter and type (ripped or smooth) in the punching area around a column or high concentrated load
- reinforcing steel for the studs acc. to EN1992-1-1 may be used with $f_{yk} \geq 500$ N/mm², in design only $f_{yk} = 500$ N/mm² is allowed
- reinforcement elements with double headed studs installed in an upright (rail at the bottom of the slab) or hanging position
- reinforcement elements with double headed studs positioned such that the double headed studs are perpendicular to the surface of the slab or footing
- reinforcement elements with double headed studs directed radially towards the column or high concentrated load and distributed evenly in the critical punching area
- reinforcement elements with double headed studs positioned such that the upper heads of the studs reach at least to the outside of the uppermost layer of the flexural reinforcement
- reinforcement elements with double headed studs positioned such that the lower heads of the studs reach at least to the outside of the lowest layer of the flexural reinforcement
- reinforcement elements with double headed studs positioned such that the concrete cover complies with the provisions according to EN 1992-1-1
- reinforcement elements with double headed studs positioned such that the minimum and maximum distances between the double headed studs on an element and between the elements as arranged around a column or area of high concentrated load complies with the provisions according to Annex B3 to B8
- The provisions are kept on site with an accuracy of $0,1 h$ (h height of the slab)

PEIKKO PSB Punching Reinforcement

Annex B1

Intended use
Specifications

English translation prepared by DIBt

Specification of intended use

- When installed correctly, the reinforcement elements have sufficient robustness to withstand usual actions before concreting.
- In case the studs are intended for use in prefabricated slabs there are no requirements in terms of before mentioned robustness if there are other possibilities to ensure a safe transport and positioning.

Packaging, transportation and storage

- Special considerations shall be given to the transportation of the prefabricated elements to avoid any damage to the anchorage of the headed studs in the precast concrete slab

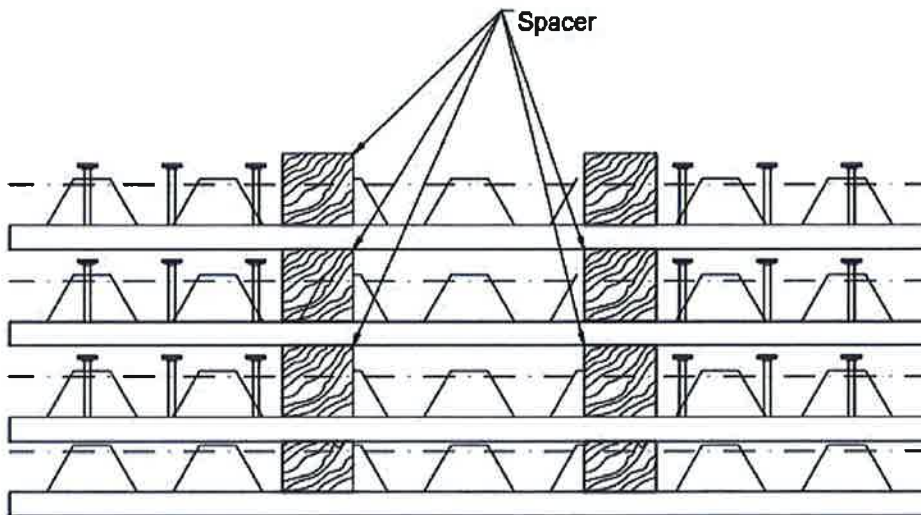

PEIKKO PSB Punching Reinforcement

Intended use
Specifications

Annex B2

Design of the PSB system element

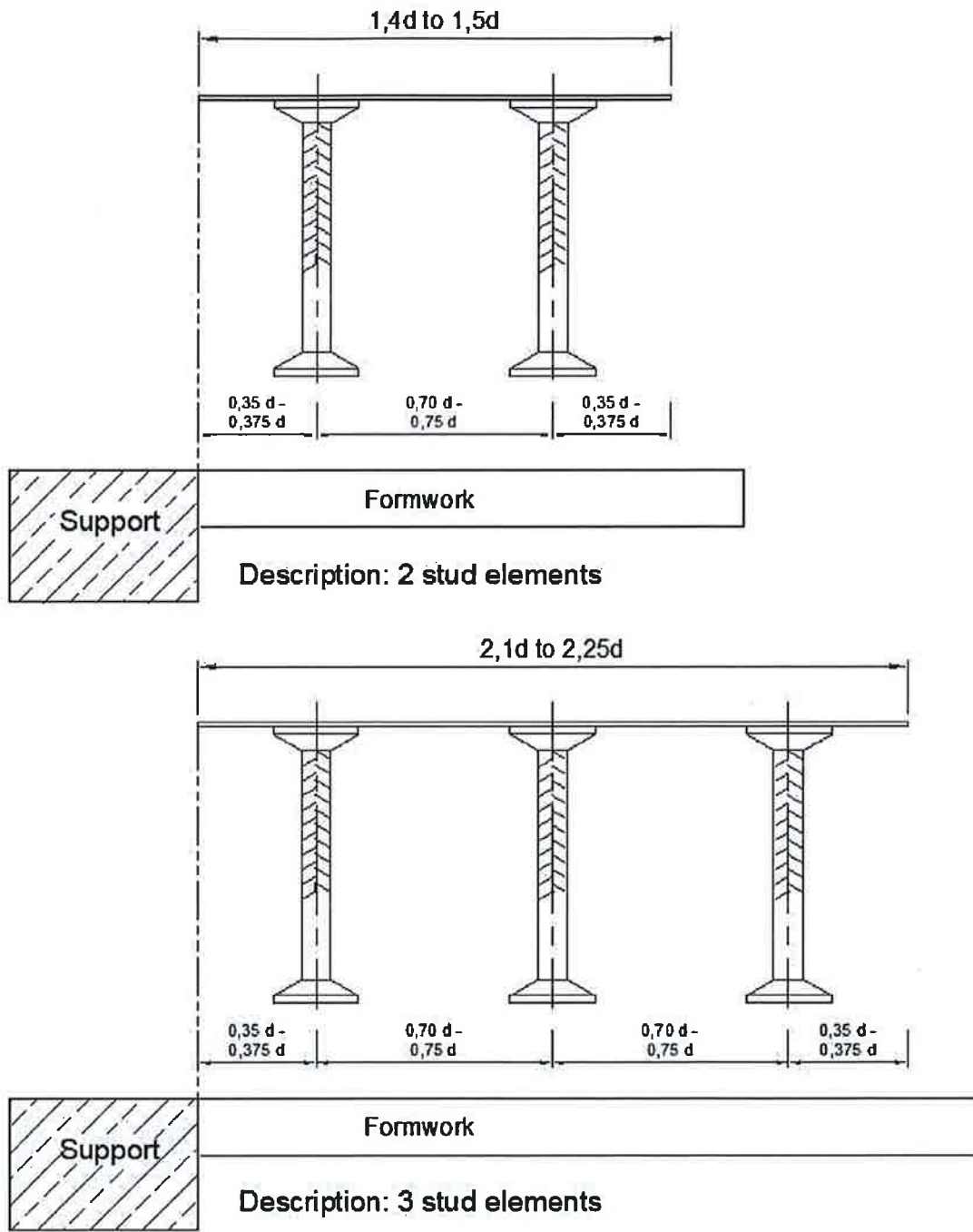

PEIKKO PSB Punching Reinforcement

Intended use
 Standard system arrangement

Annex B3

Principle arrangement of PSB studs in slabs

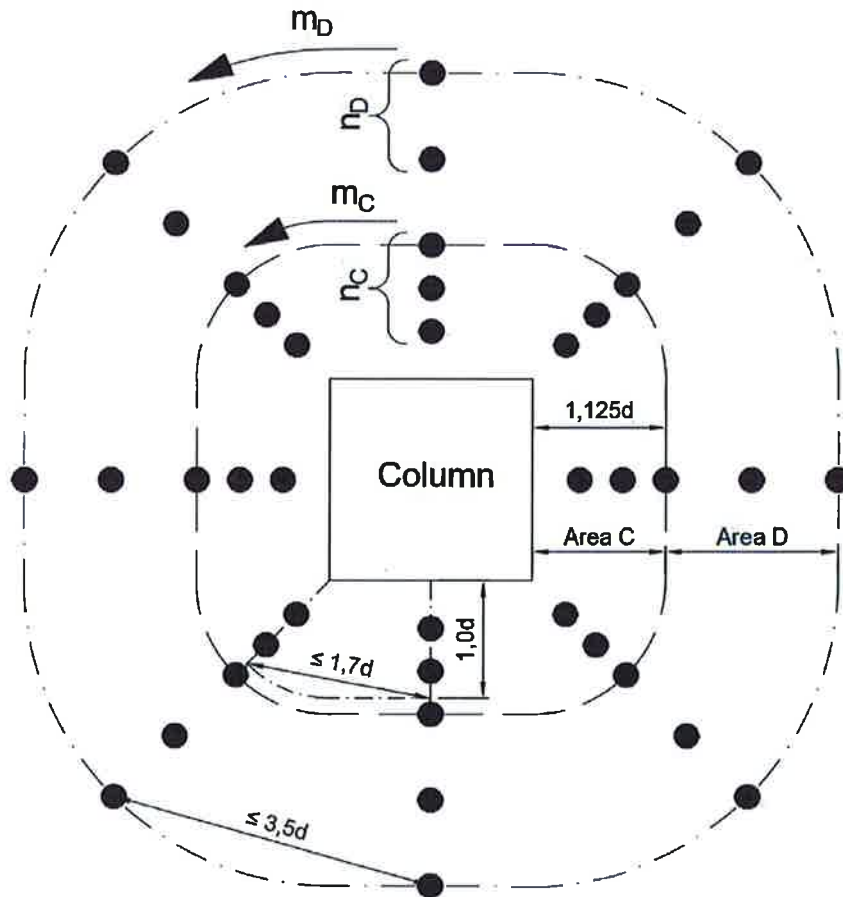

- m_C number of elements (rows) in area C
- m_D number of elements (rows) in area D
- n_C number of studs of each element (row) in area C
- n_D number of studs of each element (row) in area D

PEIKKO PSB Punching Reinforcement

Intended use
Principle arrangement of PSB Punching Reinforcement in slabs

Annex B4

Placing the punching shear reinforcement using complete elements in slab

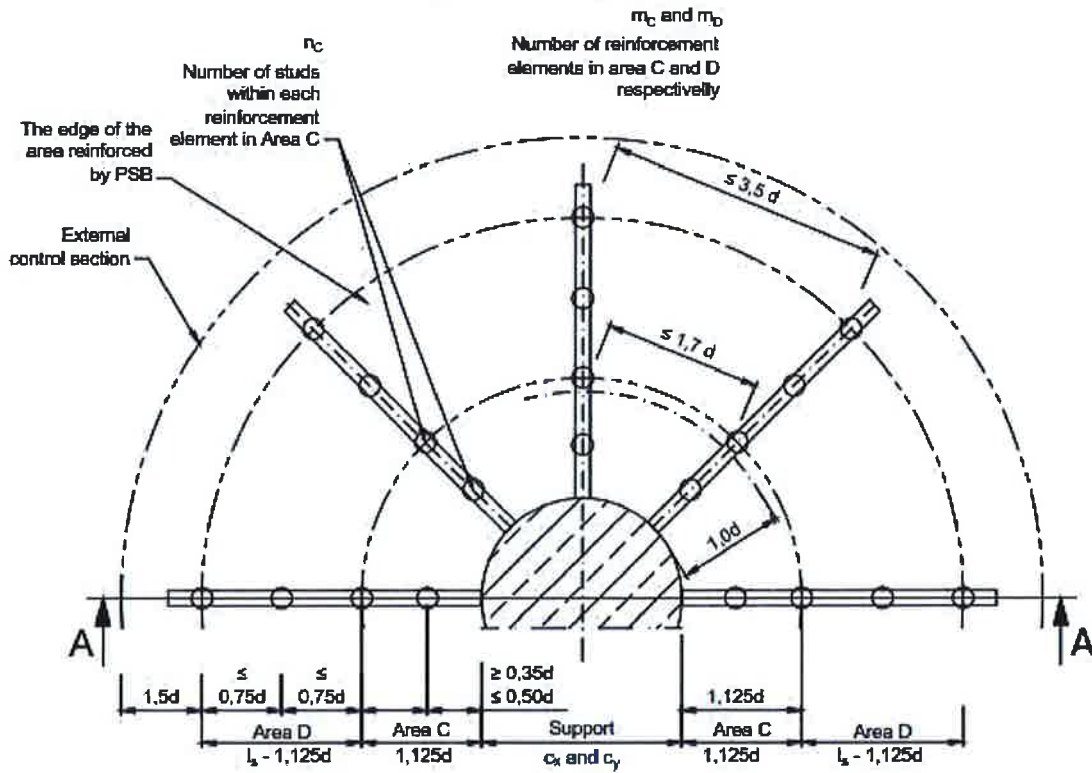

Cross section A-A "Bottom installation"

Assembly profile below the lower reinforcement layer

Cross section A-A "Top installation"

Assembly profile above the upper reinforcement layer

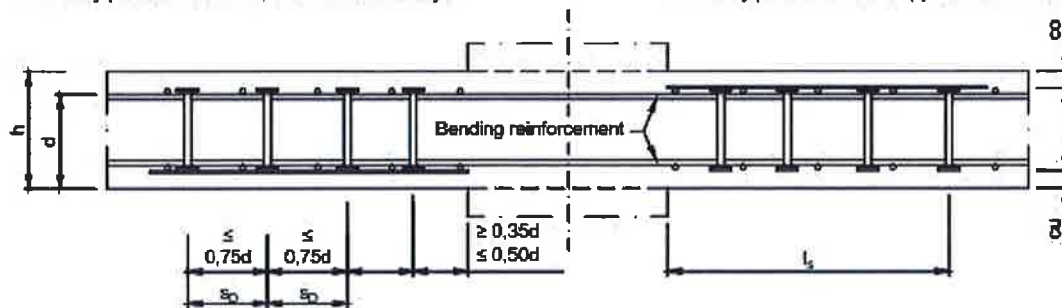

Concrete cover c_b and c_t according to EN 1992-1-1:2004, Section 4

PEIKKO PSB Punching Reinforcement

Intended use
Arrangements for PSB complete elements

Annex B5

Placing the punching shear reinforcement with 2 or 3 stud elements in slab

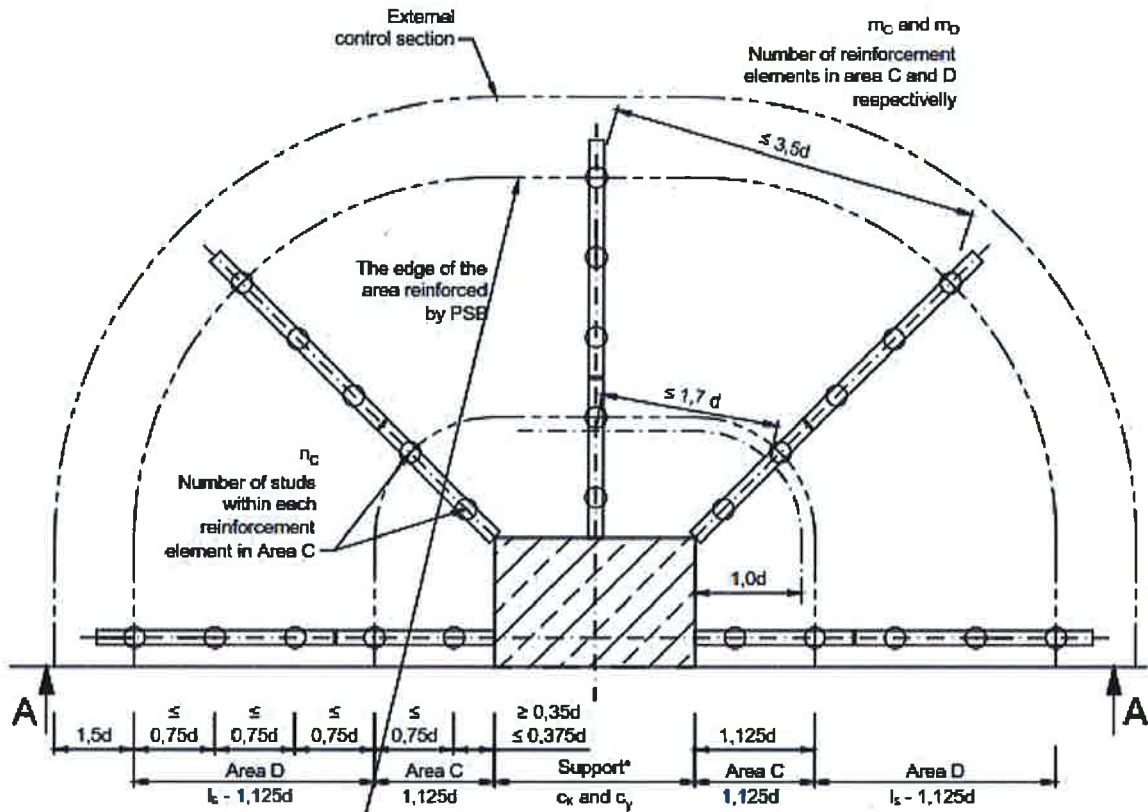

* Combination of 2 and 3 standard elements analogous with round columns

Cross section A-A "Bottom installation"

Assembly profile below the lower reinforcement layer

Cross section A-A "Top installation"

Assembly profile above the upper reinforcement layer

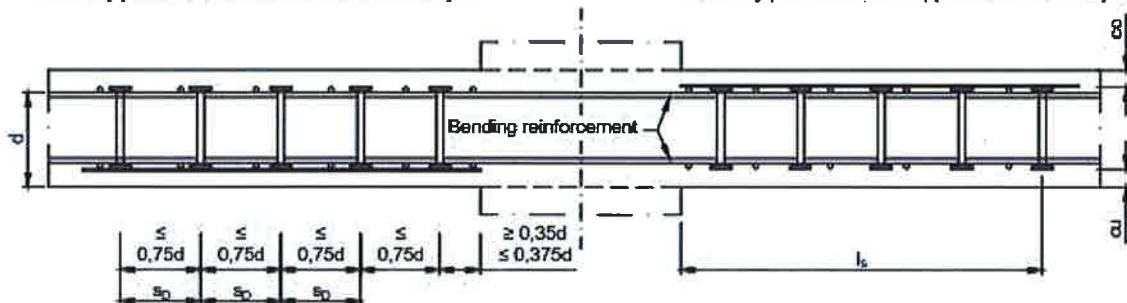

Concrete cover c_o and c_u according to EN 1992-1-1:2004, Section 4

PEIKKO PSB Punching Reinforcement

Intended use
PSB arrangement for 2 and 3 stud elements

Annex B6

Arrangement of punching shear reinforcement using complete elements in footing and ground slabs

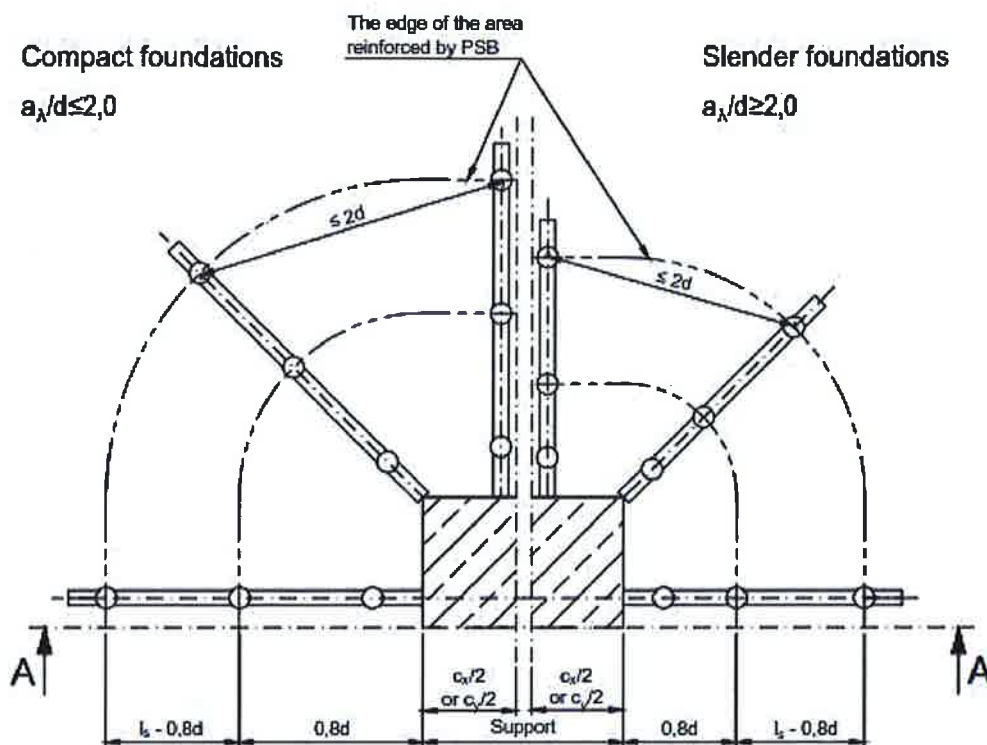

Cross section A-A "Bottom installation"

Assembly profile below the lower reinforcement layer

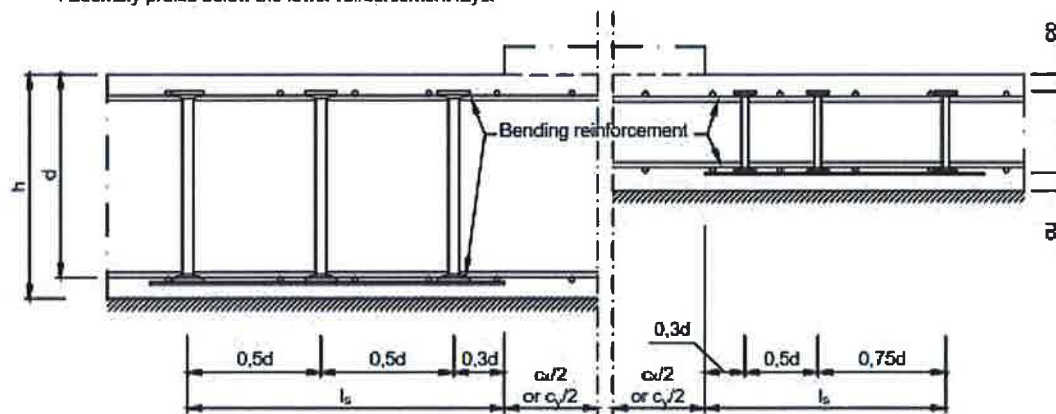

Concrete cover c_a and c_b according to EN 1992-1-1:2004, Section 4

PEIKKO PSB Punching Reinforcement

Intended use
Arrangement for PSB Punching Reinforcement elements in footings and ground slabs

Annex B7

Orthogonal arrangement of punching shear reinforcement in slab

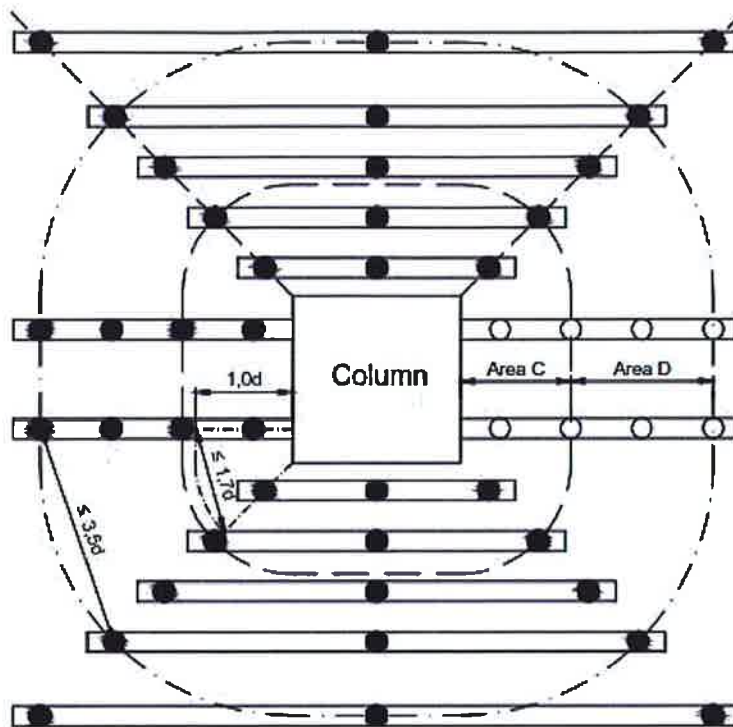

PEIKKO PSB Punching Reinforcement

Intended use
PSB parallel arrangement in slabs

Annex B8

Defining the critical perimeters u_1 and u_{out}

1. Critical perimeter u_1

a) Loaded areas (columns) are more than $6d$ from openings or slab free edges

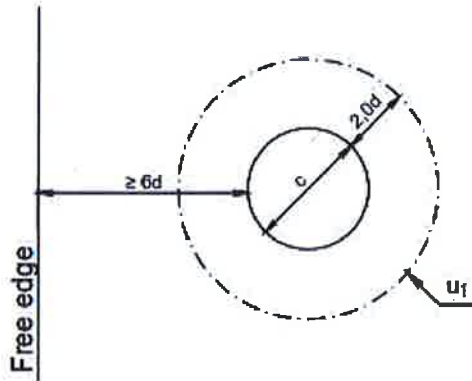

$$u_1 = \pi (c + 4d)$$

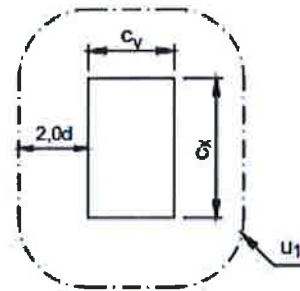

$$u_1 = 2(c_x + c_y) + 4d\pi$$

b) Loaded areas (columns) are less than $6d$ from openings (void) in the slab

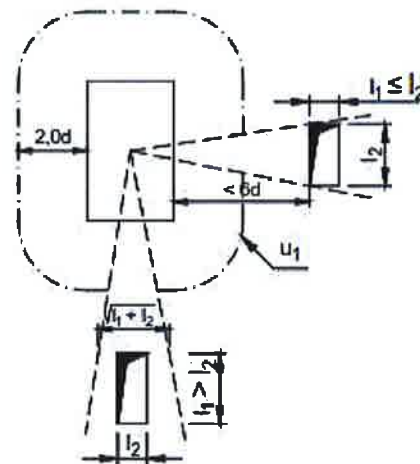
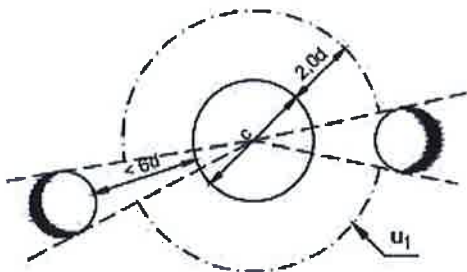

PEIKKO PSB Punching Reinforcement

Critical perimeter u_1 and outermost perimeter u_{out}

Annex C1

c) Loaded area (columns) at distances less than 6d from slab free edges

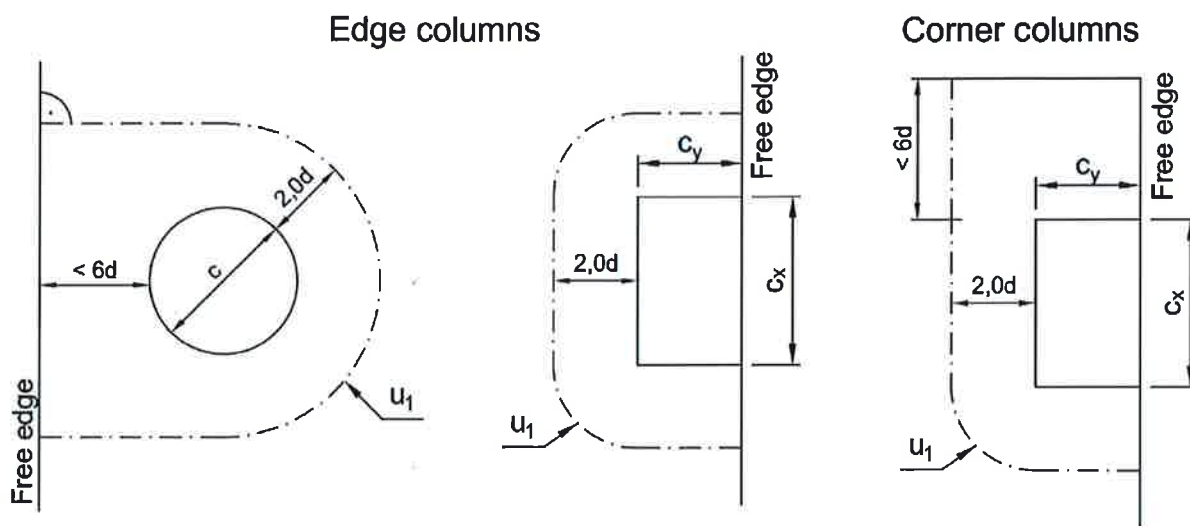

2. Outermost perimeter u_{out}

a) Loaded areas (columns) are more than 6d from openings or slab free edge

Circular column

$$u_{out} = \pi (2l_s + c + 3d)$$

Rectangular column

$$u_{out} = 2(c_x + c_y) + \pi (2l_s + 3d)$$

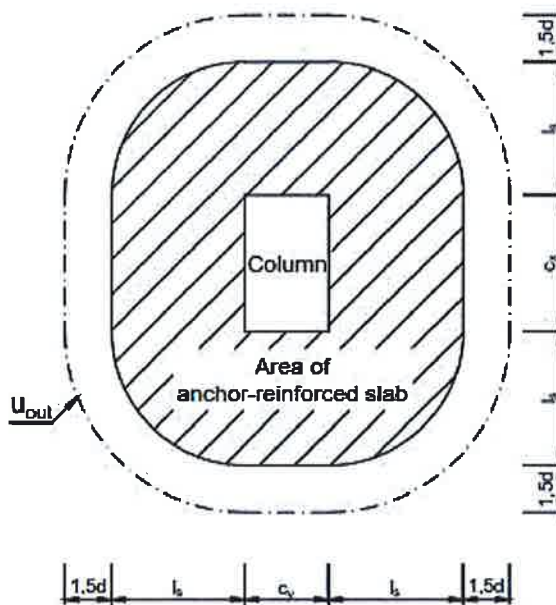
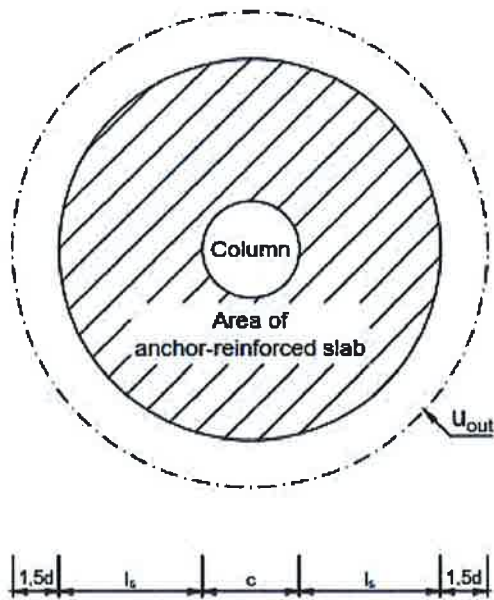

PEIKKO PSB Punching Reinforcement

Critical perimeter u_1 and outermost perimeter u_{out}

Annex C2

b) Loaded areas (columns) are less than $6d$ from openings in the slab

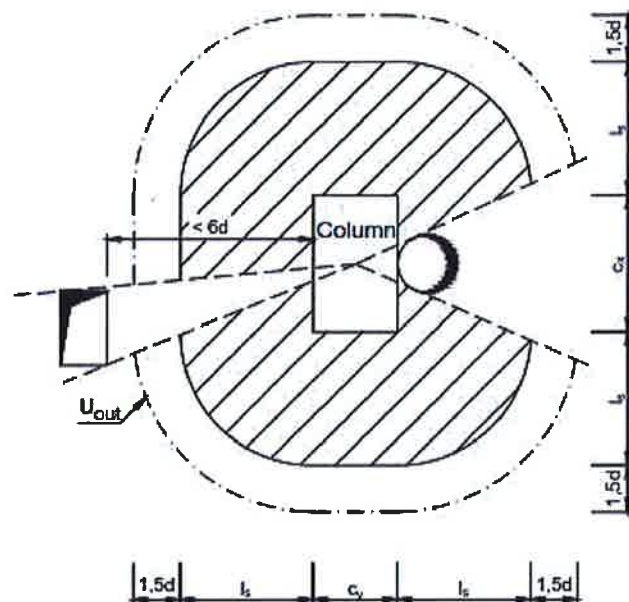

c) Loaded areas (columns) are less than $6d$ from free edge

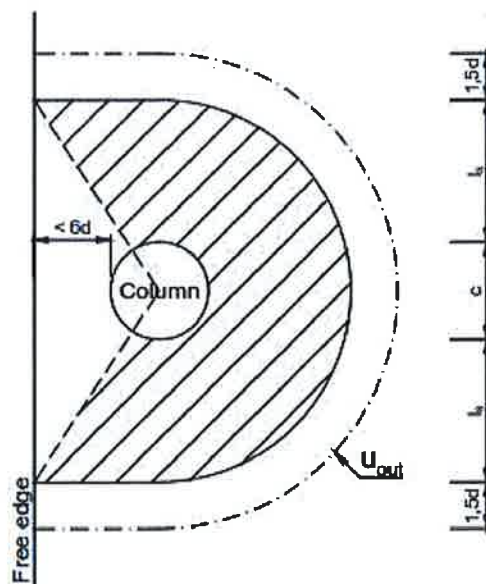

PEIKKO PSB Punching Reinforcement

Critical perimeter u_1 and outermost perimeter u_{out}

Annex C3